

The object of the study is the stress-strain state of elastomeric structures. When solving practical problems in elastomer mechanics, the issue of selecting an effective computational scheme based on computational mathematics methods arises. However, due to the insufficient number of studies, it is difficult to assess the optimality of a particular methodology, which necessitates an analysis of computational algorithms followed by a comparison of their advantages and disadvantages.

In the design of elastomeric structures, the numerical analysis of their stress-strain state is a relevant issue. One of the key characteristics is the compressibility of the material, which is not taken into account by equations for incompressible media. In thin-layer rubber elements, this effect becomes more pronounced as the ratio of one of the geometric dimensions to the thickness of the structure increases.

The use of the finite element method in displacements, despite its convenience, encounters computational errors. When the Poisson's ratio approaches 0.5, numerical instabilities arise, complicating the attainment of reliable computational results.

This study proposes a new approach to organizing computational schemes in specialized automated design systems, which ensures more accurate modeling of the stress-strain state of structures. The foundation is the use of Open Modeling Language, which simplifies the description of mechanics problems and corresponding numerical schemes within a unified variational framework.

The key result is the derivation of universal formulas for determining the potential energy of the system based on the moment finite element scheme. The proposed approach eliminates the "false shear" effect and improves the accuracy of numerical calculations for weakly compressible materials, which is confirmed by numerical analysis and experimental data

Keywords: moment finite element scheme, variational principle of Lagrange, mathematical model of elastomeric structures

DEVELOPMENT OF A PROCEDURE FOR CALCULATING PROBLEMS IN THE MECHANICS OF ELASTOMERS BASED ON THE OPEN MODELING LANGUAGE

Volodymyr Lavrik

PhD

Department of Information and Computer Technologies
Kyiv National University of Technologies and Design
Mala Shyianovska (Nemyrovycha-Danchenka) str., 2,
Kyiv, Ukraine, 01011

Ihor Bohdanov

Doctor of Pedagogical Sciences, Professor,
Corresponding Member of the National Academy
of Educational Sciences of Ukraine,
Honored Worker of Science and Technology of Ukraine, Rector
Department of Professional Education,
Labor Training and Technologies**

Hanna Aliksieieva

Corresponding author

PhD, Associate Professor*

E-mail: alekseeva@ukr.net

Oleksandr Antonenko

PhD, Associate Professor*

Oleksandr Ovsyannikov

PhD, Associate Professor*

*Department of Computer Technologies and Computer Science**

**Berdiansk State Pedagogical University

Zhukovskoho str., 55A, Zaporizhzhia, Ukraine, 69600

Received 10.01.2025

Received in revised form 12.03.2025

Accepted 31.03.2025

Published 29.04.2025

How to Cite: Lavrik, V., Bohdanov, I., Aliksieieva, H., Antonenko, O., Ovsyannikov, O. (2025).

Development of a procedure for calculating problems in the mechanics of elastomers based on the Open Modeling Language. *Eastern-European Journal of Enterprise Technologies*, 2 (7 (134)), 23–32.

<https://doi.org/10.15587/1729-4061.2025.326219>

1. Introduction

Elastomeric materials (such as rubber and elastomers) are widely used in mechanical engineering and construction. Numerical modeling of their stress-strain state is associated with certain computational problems (due to the appearance of fictitious shear strains, a "false shear effect" arises) [1]. Existing software systems are designed to solve specific classes of problems in the mechanics of deformable solid bodies. Their main advantages include ease of use, accuracy of the obtained solutions, a high level of automation, etc. [2]. However, a common drawback of these systems is that each specific system cannot be applied to solve problems that were

not anticipated by the developers during the design stage. Moreover, the user cannot choose an alternative method for solving a certain class of problems other than the one embedded in the system during its development [3].

Rubber-like materials have a unique structural composition. It is based on repeatedly recurring identical links, and their length exceeds the transverse dimensions by tens of thousands of times [4]. This causes flexibility of the molecular chains, which leads to the emergence of highly elastic properties. Therefore, elastomers have certain distinctive features [5]:

1) the ability to undergo significant deformations under the influence of external loading, whether constant or cyclically varying over time, without destruction;

2) low compressibility of the elastomer, the consideration of which creates certain computational difficulties compared to conventional materials;

3) during deformation and in a highly elastic state, the equilibrium between forces and displacements is established over a certain period of time and has a clearly pronounced relaxation character.

Although physical studies of elastomers began more than a hundred years ago, to date, there are no universal analytical methods for studying their stress-strain states. This is due to the complexity of solving the nonlinear differential equations that describe their behavior [6].

The implementation of the specific features of elastomers necessitates changes to existing calculation schemes and the development of effective numerical methods and algorithms for analysis using modern computers [7, 8].

Therefore, the development of tool systems aimed at calculating the stress-strain state of elastomer-based structures is relevant, especially for such materials (rubber and rubber-like materials), which are used in various fields of industry and engineering [9]. Due to their widespread use in the national economy, there is a need for rational design of structures based on them, taking into account efficiency and high performance quality.

2. Literature review and problem statement

In work [10], the results of research aimed at improving the finite element method for modeling three-dimensional linear-elastic bodies are presented. It is shown that traditional approximate calculation methods demonstrate low accuracy in the case of weakly compressible materials. However, issues related to the correctness of numerical modeling for materials with a Poisson's ratio close to 0.5 remain unresolved. This is due to the degeneration of the system matrices of equations, which leads to instability in the computational process.

Study [5] examines the homogenization process of multi-modulus composites. It was found that the mechanical behavior of such materials largely depends on their microstructure, which creates difficulties in constructing universal numerical models. Similar problems were identified in [11], where the effective properties of fiber-reinforced composites were investigated, taking into account the viscoelastic deformation of their components.

The methodology proposed in [12] enabled the application of a semi-analytical finite element method to spatial fracture mechanics problems. However, this approach has limitations in terms of its universal applicability, particularly in the case of nonlinear deformations. In turn, numerical modeling of viscoelastic deformation in rubber dampers, carried out in [13], confirmed the necessity of improving models for weakly compressible materials.

In works [14, 15], approximate solutions to elasticity theory problems were obtained under the assumption of material bulging on the free surface according to a parabolic law. Despite the fact that these theories start from different simple hypotheses, they lead to very similar results. This may be due to the coefficients in the stress and strain formulas, which are calculated by summing infinite series.

It should be noted that the mixed models presented in works [16–18] have several drawbacks, such as the violation of the definiteness of the equation matrix. The standard FEM used in [19, 20] demonstrates slow convergence when the Pois-

son's ratio equals 0.5, due to the polynomial functions not including terms that describe the rigid-body displacements of the elements. At the same time, the so-called "false shear effect" is present, which consists in the fact that during the bending of thin plates and shells, the use of three-dimensional FEM significantly increases the errors associated with fictitious shear deformations.

One way to overcome these difficulties is to use the moment-based finite element method, which provides more accurate modeling of weakly compressible materials. Such an approach, applied in work [21], proposes to approximate the function by expanding it in a Taylor series and subsequently discarding the n -th terms of the series, which respond to displacements and fictitious shears during deformation. This allows the main properties of rigid-body displacements to be taken into account for isoparametric and curvilinear finite elements of isotropic elastic bodies. At the same time, the exact equations of the relationship between strain and displacement are replaced with approximate ones.

All this provides grounds to assert that it is reasonable to conduct research aimed at applying the moment-based finite element scheme for the analysis of the stress-strain state of elastomeric structures.

3. The aim and objectives of the study

The aim of the study is to develop a procedure for calculating the stress-strain state of elastomeric structures using variational principles and its software implementation. This will make it possible to calculate the stress-strain state of objects, taking into account the properties of rigid displacements in elastomeric structures.

To achieve the stated aim, the following objectives were set:

- to develop a model of the stiffness matrix relationships of a tetrahedral finite element based on the moment scheme of the finite element method;
- to implement the model of the stiffness matrix relationships of a tetrahedral finite element using the problem-oriented language for describing computational schemes in elastomer mechanics – Open Modeling Language;
- to conduct a numerical analysis of the stress-strain parameters during the stretching of a double-sided blade under different stress conditions;
- to study the compression of a rubber sprocket under different mesh refinements.

4. Materials and methods of research

The object of the study is the stress-strain state of elastomeric structures.

The research hypothesis is as follows: the analysis of the stress-strain state of elastomeric structures can be adequately described using the stiffness matrix model of a tetrahedral finite element based on the moment finite element scheme. This is achieved by expanding the approximating function into a Taylor series and subsequently discarding the n -th order terms of the series, which respond to displacements and fictitious shears during deformations. In this case, the exact equations of the relationship between strain and displacement are replaced with approximate ones.

In developing the model for calculating the stress-strain state, a modification of the finite element method was used –

the moment finite element scheme (MFES) for weakly compressible materials.

The developed models and algorithms were implemented as a separate software module, which extends the functionality of the FORTU-FEM tool system, developed by scientists at Zaporizhzhia National University (Ukraine) for automating the solution of elastomer mechanics problems using MFES.

The software was implemented as a complete cross-platform product that can operate in Windows, Linux, and macOS operating systems.

The reliability of the data obtained using this software was confirmed during the course of the research.

5. Research results of the procedure for calculating the stress-strain state of elastomeric structures using variational principles and their software implementation

5.1 Model of the stiffness matrix relations of a tetrahedral finite element based on the moment scheme of the finite element method

All the relations necessary for finite element analysis can be directly derived from variational principles [21]. Fig. 1 shows one example of constructing the relations for calculating the stiffness matrix of a tetrahedral finite element using the Lagrangian variational principle.

The components of the displacement vector for this type of finite element can be described by the following relations:

$$\begin{aligned} u(x, y, z) &= \sum_{i=0}^3 u_i N_i(x, y, z), \\ v(x, y, z) &= \sum_{i=0}^3 v_i N_i(x, y, z), \\ w(x, y, z) &= \sum_{i=0}^3 w_i N_i(x, y, z), \end{aligned} \quad (1)$$

where u_i, v_i, w_i are the unknown nodal values of the displacement functions to be determined;

$N_i(x, y, z) = c_0^i + c_1^i x + c_2^i y + c_3^i z$, $c_k^i \in R$ are the shape functions of the finite element, whose c_k^i coefficients depend on the coordinates of the element and are determined from the following relation:

$$N_i(x, y, z) = \begin{cases} 1, & i=j, \\ 0, & i \neq j, \end{cases} \quad i, j=0, 1, 2, 3. \quad (2)$$

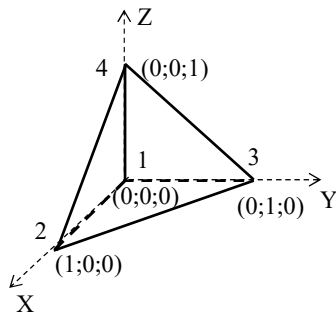

Fig. 1. Node distribution in a linear tetrahedral element

To store information about the coefficients of the displacement functions in the computer's memory, a data structure should be created (a class in terms of the object-oriented approach), which has the following form (Fig. 2).

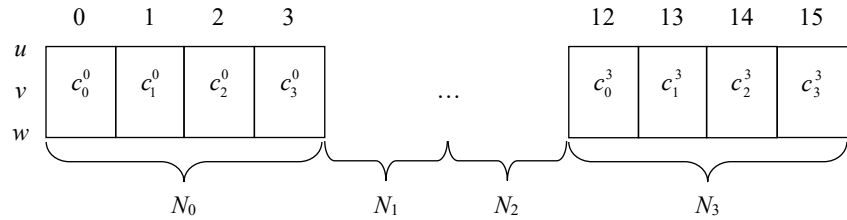

Fig. 2. Data structure for storing information about the displacement function

The formulas for calculating the components of the strain tensor can be directly derived from the Cauchy relations:

$$\begin{aligned} \varepsilon_{xx} &= \frac{\partial u}{\partial x} = \sum_{i=0}^3 v_i c_1^i, \\ \varepsilon_{yy} &= \frac{\partial v}{\partial y} = \sum_{i=0}^3 v_i c_2^i, \\ \varepsilon_{zz} &= \frac{\partial w}{\partial z} = \sum_{i=0}^3 v_i c_3^i, \\ \varepsilon_{xy} &= \frac{\partial u}{\partial y} + \frac{\partial v}{\partial x} = \sum_{i=0}^3 (u_i c_2^i + v_i c_1^i), \\ \varepsilon_{xz} &= \frac{\partial u}{\partial z} + \frac{\partial w}{\partial x} = \sum_{i=0}^3 (u_i c_3^i + w_i c_1^i), \\ \varepsilon_{yz} &= \frac{\partial v}{\partial z} + \frac{\partial w}{\partial y} = \sum_{i=0}^3 (v_i c_3^i + w_i c_2^i). \end{aligned} \quad (3)$$

According to formulas (3), the information about the elements of the strain tensor will be represented in memory in the following form (Fig. 3).

Similarly, by applying Hooke's law, the components of the stress tensor can be described as follows:

$$\begin{aligned} \sigma_{xx} &= 2G\varepsilon_{xx} + L(\varepsilon_{xx} + \varepsilon_{yy} + \varepsilon_{zz}) = \\ &= \sum_{i=0}^3 ((2G+L)u_i c_1^i + L(v_i c_2^i + w_i c_3^i)), \\ \sigma_{yy} &= 2G\varepsilon_{yy} + L(\varepsilon_{xx} + \varepsilon_{yy} + \varepsilon_{zz}) = \\ &= \sum_{i=0}^3 ((2G+L)v_i c_2^i + L(u_i c_1^i + w_i c_3^i)), \\ \sigma_{zz} &= 2G\varepsilon_{zz} + L(\varepsilon_{xx} + \varepsilon_{yy} + \varepsilon_{zz}) = \\ &= \sum_{i=0}^3 ((2G+L)w_i c_3^i + L(u_i c_1^i + v_i c_2^i)), \\ \sigma_{xy} &= G\varepsilon_{xy} = G \sum_{i=0}^3 (u_i c_2^i + v_i c_1^i), \\ \sigma_{xz} &= G\varepsilon_{xz} = G \sum_{i=0}^3 (u_i c_3^i + w_i c_1^i), \end{aligned} \quad (4)$$

where $L = \frac{2\mu G}{1-2\mu}$, $L = \frac{E}{2+2\mu}$, E is the Young's modulus and μ is Poisson's ratio.

According to formulas (4), the stress tensor for the tetrahedral finite element can be represented as follows (Fig. 4).

	0	1	2	3	...	12	13	14	15
ε_{xx}	c_1^0	0	0	0	...	c_1^3	0	0	0
ε_{yz}	$c_2^0 + c_3^0$	0	0	0	...	$c_2^3 + c_3^3$	0	0	0

Fig. 3. Data structure for storing information about the components of the strain tensor

	0	1	2	3	...	12	13	14	15
σ_{xx}	$(2G + L)c_1^0 + L(c_2^0 + c_3^0)$	0	0	0	...	$(2G + L)c_1^3 + L(c_2^3 + c_3^3)$	0	0	0
σ_{yz}	$G(c_2^0 + c_3^0)$	0	0	0	...	$G(c_2^3 + c_3^3)$	0	0	0

Fig. 4. Data structure for storing information about the components of the stress tensor

The scheme for deriving the differential equations of the theory of elasticity from the Lagrangian variational principle can be represented as the internal strain energy using the following formula:

$$\delta W = \iiint \sigma^{ij} \delta \varepsilon_{ij} dV. \tag{5}$$

After substituting the relations from formulas (2)–(4) into formula (5), the variation of the elastic strain energy was expressed in the following form. The formula must be complete:

$$\begin{aligned} \delta W = & \delta \int \sum_{i=0}^3 \left((2G + L)u_i c_1^i + L(v_i c_2^i + w_i c_3^i) \right) \cdot \sum_{i=0}^3 u_i c_1^i + \\ & + \int \sum_{i=0}^3 \left((2G + L)v_i c_2^i + L(v_i c_1^i + w_i c_3^i) \right) \cdot \sum_{i=0}^3 v_i c_2^i + \\ & + \int \sum_{i=0}^3 \left((2G + L)w_i c_3^i + L(u_i c_1^i + v_i c_2^i) \right) \cdot \sum_{i=0}^3 w_i c_3^i + \\ & + G \int \sum_{i=0}^3 (u_i c_2^i + v_i c_1^i) \cdot \sum_{i=0}^3 (u_i c_2^i + v_i c_1^i) + \\ & + G \int \sum_{i=0}^3 (u_i c_3^i + w_i c_1^i) \cdot \sum_{i=0}^3 (u_i c_3^i + w_i c_1^i) + \\ & + G \int \sum_{i=0}^3 (v_i c_3^i + w_i c_2^i) \cdot \sum_{i=0}^3 (v_i c_3^i + w_i c_2^i) dV. \end{aligned} \tag{6}$$

As a result of applying the method of variation of an arbitrary constant to formulas (6), the desired relationships for calculating the coefficients of the local stiffness matrix of the tetrahedral finite element were obtained:

$$K = V \begin{bmatrix} k_{0,0} & k_{0,1} & \dots & k_{0,11} \\ k_{0,1} & k_{1,1} & \dots & k_{1,11} \\ & & \dots & \\ k_{0,11} & k_{1,11} & \dots & k_{11,11} \end{bmatrix}, \tag{7}$$

where V is the volume of the finite element;

$$k_{0,0} = (2G + L)(c_0^1)^2 + G((c_0^2)^2 + (c_0^3)^2),$$

$$k_{0,1} = (G + L)c_0^1 c_0^2,$$

$$k_{0,2} = (G + L)c_0^1 c_0^3,$$

and so on.

It should be noted that the coefficients of the matrix K can be easily calculated automatically, so all the formulas for their calculation are not provided further.

Obviously, to implement such an approach for deriving the relationships that define the coefficients of the stiffness matrix for a given type of finite element, a certain formal tool [22] is required.

5.2. Software implementation of the moment method for finite elements using open modeling language in elastomer mechanics

The use of computational technology for modeling the stress-strain state of elastomer structures with the application of the aforementioned approach requires formal tools for describing variational principles and the rules for deriving the corresponding calculation relationships [23, 24].

To automate the description of such models, specialized domain-specific languages (DSL) [4, 25] are practically used, which allow for the formal description of mathematical models of arbitrary complexity.

The description of any formal language (DSL or programming language) must unambiguously and consistently define its syntax and semantics. The syntax of a domain-specific language refers to the rules used to describe its structure. Accordingly, semantics refers to a specific set of rules for interpreting the meaning (content) of the language constructs. The formal grammar of such a language is formed as the set of its syntactic rules.

In practice, the extended Backus-Naur form (EBNF) [26, 27] is most commonly used for the formal description of DSLs and algorithmic languages, where all syntactic constructs are successively expressed through one another.

The structure of the description of the mathematical model of an elastomer structure and the scheme for its calculation using the OML language in the EBNF notation can be represented as follows:

- 1) OML-description – declaration-block operator-block.
- 2) Declaration-block – geometry-model-description resulting-functions-description argument-description constants-description auxiliary-functions-description variational-principles-description:
 - geometry-model-description – “MODEL” mesh-file EOL;
 - mesh-file – full-file-name;
 - resulting-functions-description – “RESULT” identifier [,{identifier}] EOL;
 - argument-description – “ARGUMENT” identifier [,{ identifier}] EOL;
 - constants-description – “CONSTANT” identifier-declaration [,{ identifier-declaration }] EOL;
 - auxiliary-functions-description – “FUNCTION” identifier-declaration [,{ identifier-declaration }] EOL;
 - variational-principles-description – “FUNCTIONAL” identifier-declaration [,{ identifier-declaration }] EOL;
 - operator-block – identifier-declaration boundary-conditions-description;

– boundary-conditions-description – identifier “(“ logical-expression “)” – arithmetic-expression EOL.

Here, EOL denotes the end of the line.

It should be noted that when describing boundary conditions, only the name of a variable declared in the resulting functions section can be used as an identifier.

From the description above, it is clear that the calculation scheme of the elastomer mechanics problem consists of three logical sections:

1) declaration of the list of variables used in the calculations;

2) description of the necessary relationships and formulas (this section is not mandatory, as all necessary relationships can be set during the initialization of constants and variables);

3) description of boundary conditions.

This can be schematically represented as follows:

! General structure of the OML-description for the elastomer mechanics problem

```

MODEL <file-name>
RESULT u, v, w
ARGUMENT x, y, z
CONSTANT E, m, G, L
FUNCTION Exx, Eyy, Ezz, Exy, Exz, Eyz, Sxx, Syy, Szz,
Sxy, Sxz, Syz
FUNCTIONAL U
    
```

! Description of constants

```

E = 5E+6
m = 0.49
    
```

! Description of auxiliary formulas

```

Exx = diff(u, x)
...
    
```

! Description of the final variational principle

```

U = 0.5*VolumeIntegral(Sxx var Exx + Syy var Eyy +
Szz var Ezz +
Txy var Gxy + Txz var Gxz + Tyz var Gyz)
    
```

! Description of boundary conditions

```

u(x^2 + y^2 - 9 == 0) = 0
...
    
```

This structure for describing the mathematical model of an elastomer structure in the OML language is convenient and intuitive for the user.

Proof of completeness and consistency of the OML language.

Theorem 1. The domain-specific language OML is algorithmically complete.

Proof. According to the theory of computability, a formal symbolic system is algorithmically complete (Turing-complete) if any computable function can be implemented using it. To prove this theorem, it is necessary to show that in the OML language, any function F maps the set of real numbers to the set of real numbers (i.e., it belongs to the class of computable functions $F: \mathbb{R} \rightarrow \mathbb{R}$, where \mathbb{R} the set of real numbers). According to the semantics of the OML language, any of its functions returns a real number, a vector of real numbers, or a matrix of real numbers, with the dimensions depending on the type of finite element applied.

Therefore, according to the Church-Turing thesis, any function F that can be computed by a physical device can also

be computed by a Turing machine. Thus, it follows that any formula F in the OML language is computable.

The theorem is proven.

Theorem 2. The domain-specific language OML is consistent.

Proof. The proof of this theorem is conveniently done by contradiction. Suppose that the OML language is inconsistent. Then, there must exist at least one formula F for which the relation $F = \bar{F}$ is true. That is, the formulas F and \bar{F} must be identically true. According to the syntax and semantics of the OML language, this is impossible, as the logical negation of any non-zero arithmetic expression is identically equal to zero. If inversion is applied to an expression whose value is zero, the result will yield a non-zero value (usually one). Therefore, it is impossible to write a formula F in the OML language for which the values of F and \bar{F} and would be identical.

The theorem is proven.

The proposed scheme for deriving calculation relationships from variational principles is universal and independent of the type of finite element. Its application allows the creation of instrumental automated systems for the design and finite element analysis of complex elastomer structures, where the user can define the numerical calculation algorithm for the problem.

This approach allows for the most adequate modeling of the stress-strain state of elastomeric material structures, which require the application of specialized theories and calculation methods. However, its practical implementation requires a certain formal way of describing variational formulas.

5.3. Numerical analysis of the stress-strain parameters of a bilateral blade under different stresses

In elastomer mechanics, the method for determining the elastic properties of rubber under tension is used. The strength of materials, the relative elongation at rupture, and the stress at a given elongation are studied. The essence of the method is that the sample is fixed at both ends and stretched at a constant speed until rupture occurs.

The test samples are in the form of a bilateral blade (Fig. 5). They are cut from vulcanized plates with a thickness of (2.0 ± 0.2) using special knives.

Since the investigated blade is symmetrical, only half of the object was used for calculating the stress-strain state. One end is firmly fixed, while force is applied to the other end (Fig. 6).

Using the preprocessor of the FORTU-FEM system, a regular finite element model of the blade was constructed, consisting of 1463 nodes and 4347 elements (Fig. 7).

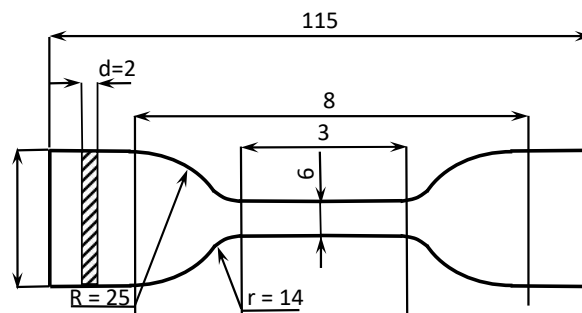

Fig. 5. Test sample in the form of a bilateral blade

Fig. 8 shows an example of the displacement distribution along the entire sample in different directions. The material used in this case is “heat-resistant rubber” with the following

characteristics: Young's modulus $E=2.8 \times 10^3$ GPa, Poisson's ratio $\nu=0.49$. The distributed load applied to the unrestrained end is $q=14$ GPa.

When studying the stress-strain state of an elastomeric element, tensile stresses are of the greatest interest. The nature of the growth of normal stresses is shown in Fig. 9.

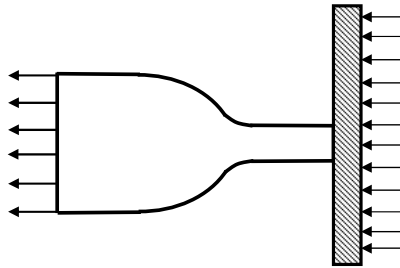

Fig. 6. Boundary condition for fixing the test sample in the form of a blade

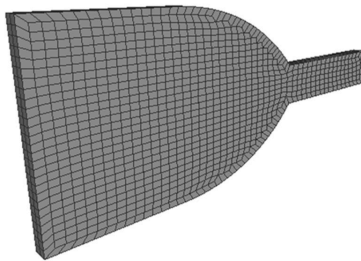

Fig. 7. Discrete model of the blade

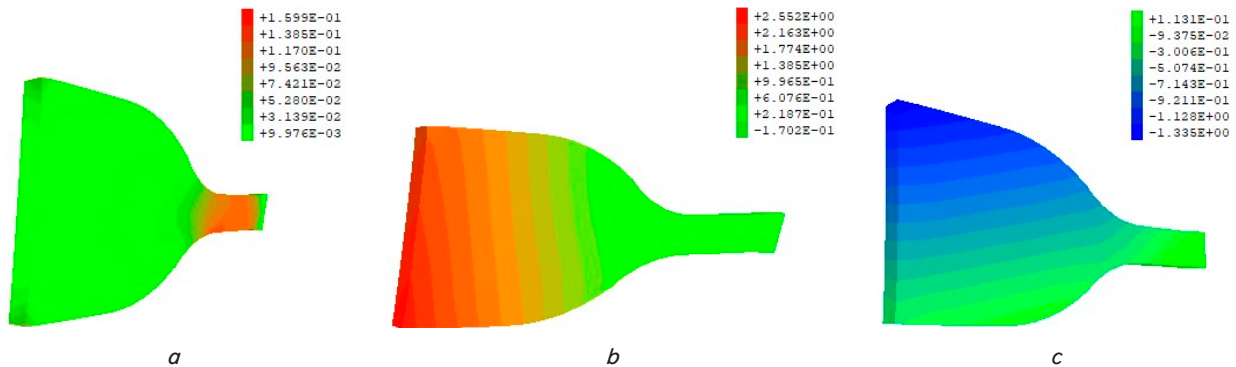

Fig. 8. Distribution of stresses in different directions: *a* – along the x-axis; *b* – along the y-axis; *c* – along the z-axis

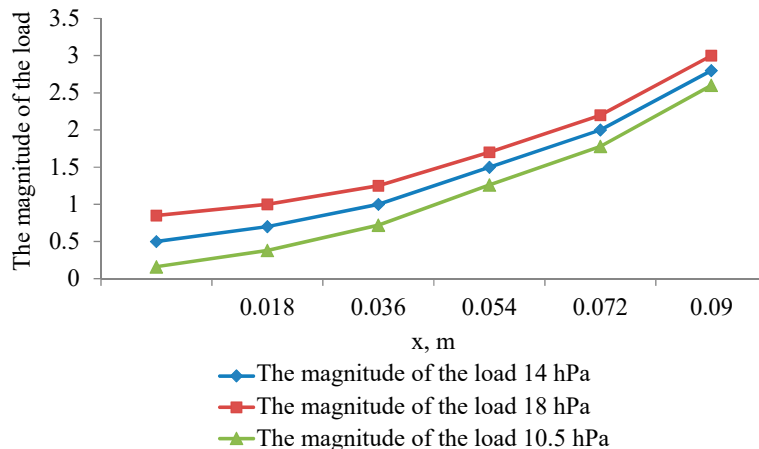

Fig. 9. Distribution of normal stresses in the blade under different loads

Analysis of the results shows that when studying the blade, the moment scheme of the finite element method used in the OML system for calculating structures in a stress-strain state confirms the adequacy of the obtained results presented in the technical documentation.

During the study of the stretching problem of the bilateral blade, the relative elongation is 18 %. This result matches the data presented in [28].

5. 4. Study of the compression of a rubber sprocket-shaped element under different mesh refinements

The following example presents the results of a study on the elastic cam clutch with a sprocket-shaped element, designed for coaxial connection of shafts in mechanisms, such as a gearbox and an electric motor (Fig. 10).

The work compares two methods: the finite element method based on the FORTU-FEM instrumental system and the moment scheme of the finite element implemented in OML.

This coupling is made of two half-couplings, between which a rubber sprocket element is placed. The teeth of the sprocket work in compression. When transmitting torque, half of the teeth are engaged in each direction. The functionality of the rubber sprocket is determined by the magnitude of the compressive stresses.

Sprockets for elastic cam clutches are designed for the connection of coaxial cylindrical shafts when transmitting a torque from 2.5 to 400 N·m and reducing dynamic loads. The parameters of the sprocket for the calculation are shown in Fig. 11.

The calculation of the object was performed with the orientation of the torque counterclockwise, with the load applied to each tooth at points maximally distant from the center of the sprocket. The material characteristics were taken from the technical plastic TMKIII-C GOST 7338-90.

Finite element discretization in this study was carried out using tetrahedral and hexahedral elements (Fig. 12).

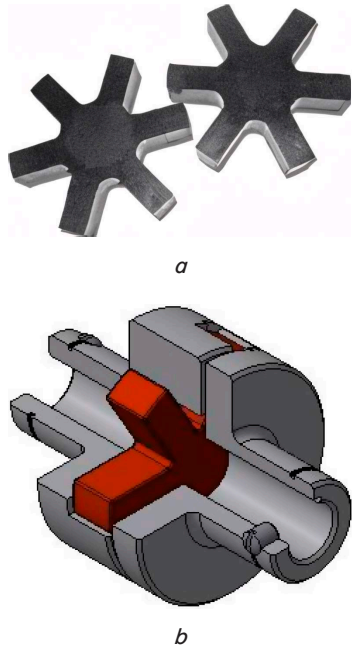

Fig. 10. Rubber sprocket: *a* – rubber sprocket (external view); *b* – rubber sprocket in the elastic coupling [29]

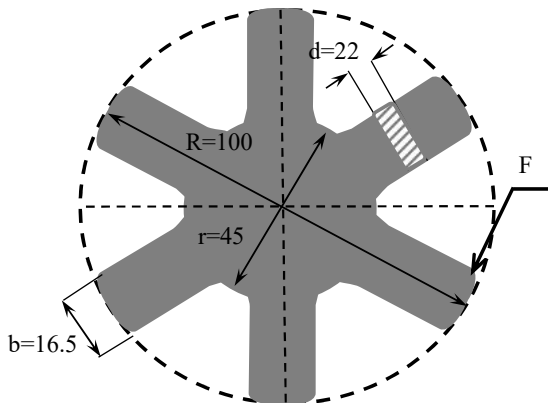

Fig. 11. Sample for the calculation of the rubber sprocket

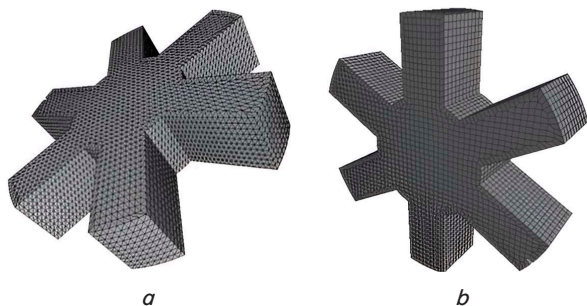

Fig. 12. Finite element representation of the rubber sprocket: *a* – using tetrahedral finite elements; *b* – using hexahedral finite elements

The displacement distribution in different directions is shown in Fig. 13.

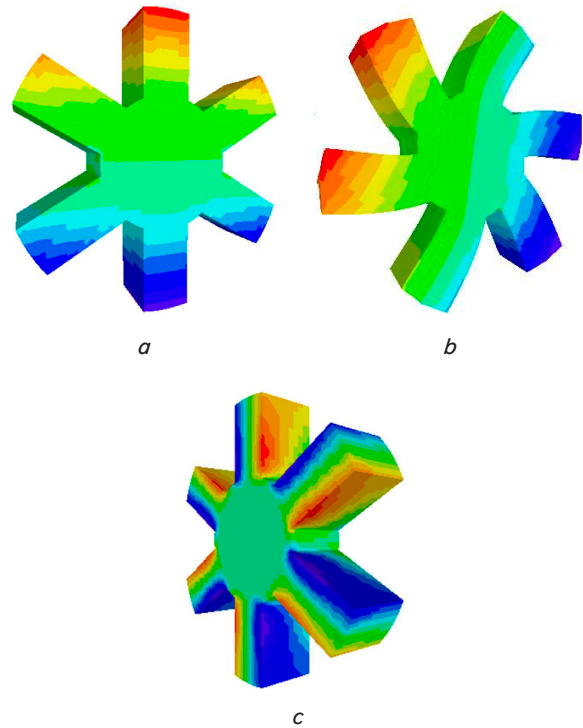

Fig. 13. Displacement distribution in different directions: *a* – along the X-axis; *b* – along the Y-axis; *c* – along the Z-axis

In the case of using the Finite Element Method (FEM), the object was divided into 15,169 nodes and 74,154 finite elements, while using the Mid-Spherical Finite Element Method (MSFEM), it was divided into 15,169 nodes and 12,359 finite elements.

Table 1 shows the results of the calculation of the load applied to each tooth of the sprocket at the upper point. The torque for the study was 10 N·m and was directed counterclockwise.

Table 1

Calculation results for the sprocket

Poisson's ratio, ν	Young's modulus, Pa	Maximum deflection of the sprocket (standard FEM scheme), $m \cdot 10^{-5}$	Maximum deflection of the sprocket (MSFEM), $m \cdot 10^{-5}$
0.470	90,000	4.784	4.221
0.473	90,000	4.685	4.145
0.478	100,000	5.103	4.999
0.480	100,000	5.035	4.837
0.482	100,000	5.012	4.821
0.488	100,000	5.001	4.801
0.490	100,000	4.957	4.789
0.492	100,000	4.942	4.752
0.496	100,000	4.901	4.723
0.499	110,000	5.309	5.123
0.4999	110,000	5.267	5.089

To verify the effectiveness of the calculation schemes, numerical results of calculations using different methods in the FORTU-FEM system were compared (Fig. 14).

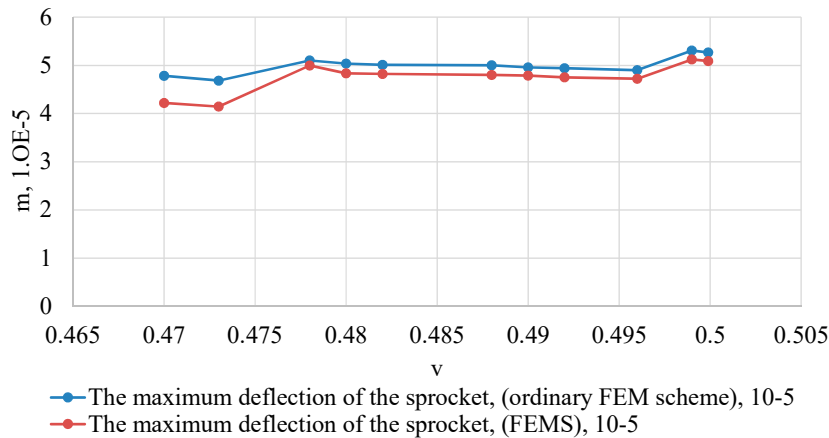

Fig. 14. Comparative graphs of the deflection of the sprocket element as a function of Poisson's ratio depending on the calculation scheme

The results of numerical modeling of structures made from compressible materials proved to be significantly more accurate when using the moment-based finite element method, ensuring their closeness to analytical solutions.

6. Discussion of the results of modeling the mechanical behavior of elastomeric structures

The results of the study, which were aimed at using the moment-based finite element scheme for analyzing the stress-strain state of elastomeric structures, are explained by two key aspects. First, the moment-based finite element scheme was applied to model the stress-strain state of elastomeric structures. Second, additional factors that were not considered in previous studies were taken into account during the numerical analysis.

The paper applies Lagrange's variational principle, which allows obtaining relationships for calculating the stiffness matrix of the tetrahedral finite element (Fig. 1), an important step in the numerical modeling of elastomeric structures.

To store information about the coefficients of displacement functions (2), strain tensor elements (3), and stress tensor elements (4) in the computer's memory, an appropriate data structure was created, as shown in Fig. 2–4. This is an optimal approach that ensures efficient data storage and processing, simplifies access to necessary information, and reduces computational costs. Thanks to this data organization, it is possible to quickly perform calculations required for analyzing the stress-strain state of structures, as well as integrate the obtained results into further calculations or numerical simulations.

The stiffness matrix (7), obtained based on the moment-based finite element method (6), eliminates errors inherent in traditional methods, particularly by considering the effects of spurious shear, rigid displacements, and low compressibility, which are characteristic of elastomeric materials.

During the study of the stress-strain state of elastomeric structures, the traditional finite element method, based on the discretization of a continuous body into a finite number of interacting elements at nodes, was widely used. This approach provided approximation of complex geometrical shapes and loading conditions. However, during the modeling of elastomeric materials, which are characterized by low compressibility and high values of Poisson's ratio (close to 0.5), numerical instability and a decrease in the

accuracy of results were observed. This is due to the degeneracy of the stiffness matrix, leading to inaccurate results.

In contrast to the traditional finite element method, the moment-based finite element scheme took into account additional moments and deformations, which contributed to improved accuracy in modeling elastomeric materials. Its application provided a more accurate description of the stress-strain state of low-compressibility materials, reducing errors caused by the spurious shear effect. This is particularly important when analyzing structures with a high Poisson's ratio, where standard methods show significant errors.

The results of the stretching of the bilateral rib (Fig. 9) showed that as the load increased, the difference in relative elongations decreased, which was consistent with data from the literature. The analysis of the rubber sprocket (Table 1, Fig. 14) confirmed the higher accuracy of the moment-based scheme in the Poisson's ratio range of 0.470–0.4999, representing a significant improvement compared to traditional FEM methods, which have reduced accuracy when modeling low-compressibility materials. The application of the moment-based scheme eliminated the instability of calculations caused by the degeneracy of equation matrices and ensured the correctness of the obtained results even in critical material parameter ranges.

The analysis of the obtained results highlights the following features:

1. The use of the moment-based finite element scheme ensured high accuracy in modeling the stress-strain state of elastomeric materials, as confirmed by the analysis of contact stresses and displacements in various geometric configurations.
2. In cases of high Poisson's ratios, traditional methods showed significant errors, whereas the moment-based scheme provided results that were well aligned with analytical solutions.
3. The integration of Open Modeling Language enabled the universalization and automation of the calculation process for different types of finite elements, reducing the need for individual algorithm customization for each specific case.

The proposed approach significantly improved the accuracy of calculations for the stress-strain state of elastomeric structures and allowed for the elimination of key drawbacks inherent in traditional analysis methods. However, despite its advantages, the application of the moment-based finite element method requires considerable computational resources, making it difficult to perform calculations for large-scale structures. At the same time, for isotropic and low-compressibility materials, this approach proved to be particularly effective.

The study's limitations are that the advanced model of numerical analysis of elastomeric structures, although accounting for additional factors, is still based on certain assumptions about material properties, which may not fully reflect the behavior of real elastomers under complex operating conditions. Furthermore, the study was conducted without considering the effect of long-term cyclic loading and material degradation, which could influence the long-term operational reliability of the structures.

Future development of the work may include expanding the capabilities of Open Modeling Language for modeling

nonlinear deformation processes, improving adaptive mesh refinement, and developing new variational principles to enhance the accuracy of numerical analysis.

7. Conclusions

1. The developed mathematical model accounted for rigid displacements, the effect of spurious shear, and the low compressibility of elastomers, which ensured high accuracy in the calculations of the mechanical properties of materials. The proposed scheme for deriving calculation relations based on variational principles turned out to be universal and independent of the type of finite element. Its application contributed to the development of automated design and numerical analysis systems for complex elastomeric structures, allowing users to independently determine the calculation algorithm. Additionally, the considered approach ensured high calculation accuracy in cases where Poisson's ratio approached 0.5. The use of the moment-based finite element scheme eliminated the spurious shear effect and achieved asymptotic convergence of the results during mesh refinement.

2. During the research, a software implementation of the moment-based finite element scheme was carried out using the problem-oriented language Open Modeling Language, designed for describing computational schemes in elastomer mechanics tasks. The proposed methodology for forming calculation relations based on variational principles in the Open Modeling Language environment turned out to be universal and independent of the type of finite element. Its application enabled the development of instrumental automated systems for the design and finite element analysis of complex elastomeric structures, with the ability to flexibly form algorithms for numerical calculation.

3. A numerical analysis of the stress-strain state parameters of a bilateral blade under different loading levels was performed. The implemented model demonstrated high effectiveness, as confirmed by its accuracy: the maximum deviations between numerical calculations and experimental data do not exceed 5 %, and the average deviation is 3.7 %. The results show that under loading, the maximum displacement is 0.09 mm, which is consistent with theoretical and experimental data. This confirms the model's suitability for further use in engineering calculations and structural optimization.

4. The compression process of a rubber sprocket was studied at different mesh refinement levels. The analysis of the

obtained results showed that the use of the moment-based finite element scheme provides significantly higher calculation accuracy compared to standard FEM methods. Specifically, when modeling low-compressibility materials such as rubber, traditional methods demonstrate significant errors in regions with high Poisson's ratios ($\nu \rightarrow 0.5$), due to the degeneracy of the stiffness matrices. In the case of classical FEM, the maximum stress error in critical zones reached 17 %, while the moment-based scheme reduced this to 3 %. Unlike classical FEM, where computational errors can significantly affect results when compressing almost incompressible materials, the moment-based scheme accounts for additional moments and deformations. This allows for a more accurate reproduction of the material's physical behavior and avoids the spurious shear effect. In particular, the maximum deformations obtained using the moment-based scheme differed from analytical solutions by no more than 3.2 %, indicating the high reliability of the results.

Conflict of interest

The authors declare that they have no conflict of interest regarding the current research, including financial, personal, authorial, or any other conflicts that could affect the research or the results presented in this document.

Financing

No funding was received for conducting this research.

The authors have no financial or property interests in any material discussed in this article.

Data availability

All data is available both in numerical and graphical form in the main text of the manuscript.

Use of artificial intelligence

The authors confirm that no artificial intelligence technologies were used in the creation of this work.

References

1. Biderman, V. L., Sukhova, N. A. (1968). Calculation of cylindrical and rectangular long rubber compression shock absorbers. *Strength of Materials*, 13, 55–72.
2. Bulat, A. F., Dirda, V. I., Karnaukhov, V. G., Agal'tsov, G. M. (2021). Effect of Ionizing Radiation on the Mechanical Behavior of Rubber Materials. *International Applied Mechanics*, 57 (4), 379–385. <https://doi.org/10.1007/s10778-021-01089-z>
3. Drass, M. (2020). Elastomers and their Mechanical Behaviour. *Constitutive Modelling and Failure Prediction for Silicone Adhesives in Façade Design*, 37–63. https://doi.org/10.1007/978-3-658-29255-3_3
4. Feng, H., Zhou, J., Gao, S., Jiang, L. (2021). Finite element simulation of the viscoelastic behavior of elastomers under finite deformation with consideration of nonlinear material viscosity. *Acta Mechanica*, 232 (10), 4111–4132. <https://doi.org/10.1007/s00707-021-03042-0>
5. Grebenyuk, S., Smoliankova, T., Klymenko, M., Kudin, O. (2020). The homogenization of multimodular composites at their longitudinal deformation. *Eastern-European Journal of Enterprise Technologies*, 3 (7 (105)), 13–19. <https://doi.org/10.15587/1729-4061.2020.199968>
6. Zhang, L., Yu, W. (2015). Variational asymptotic homogenization of elastoplastic composites. *Composite Structures*, 133, 947–958. <https://doi.org/10.1016/j.compstruct.2015.07.117>
7. Martynenko, V. G., L'vov, G. I. (2016). A numerical method for determining anisotropic visco-elastic properties of orthogonally reinforced composite material. *Vestnik NTU «KhPI». Series: Dynamics and Strength of Machines*, 46 (1218), 44–51.

8. Nikishkov, G., Nikishkov, Y., Makeev, A. (2013). Finite element mesh generation for composites with ply waviness based on X-ray computed tomography. *Advances in Engineering Software*, 58, 35–44. <https://doi.org/10.1016/j.advengsoft.2013.01.002>
9. Dyrda, V., Lapin, V., Lysytsia, M., Puhach, A., Bulat, I., Pankevych, I. et al. (2022). Some problems of the new radiation-resistant rubber mechanics in vibrating machines at hard γ -radiation. *IOP Conference Series: Earth and Environmental Science*, 970 (1), 012017. <https://doi.org/10.1088/1755-1315/970/1/012017>
10. Mezhuyev, V., Lavrik, V. (2015). Improved Finite Element Approach for Modeling Three-Dimensional Linear-Elastic Bodies. *Indian Journal of Science and Technology*, 8 (30). <https://doi.org/10.17485/ijst/2015/v8i1/57727>
11. Bulat, A. F., Dyrda, V. I., Grebenyuk, S. M., Klymenko, M. I. (2020). Determination of Effective Characteristics of a Fibrous Composite with Account of Viscoelastic Deformation of its Components. *Strength of Materials*, 52 (5), 691–699. <https://doi.org/10.1007/s11223-020-00221-7>
12. Gulyar, A. I., Sakharov, A. S., Stepashko, V. I. (1986). Application of the semianalytical finite element method to solving spatial problems of fracture mechanics of axisymmetric bodies. *Strength of Materials*, 18 (7), 959–963. <https://doi.org/10.1007/bf01522700>
13. Bulat, A. F., Dyrda, V. I., Grebenyuk, S. M., Klymenko, M. I. (2022). Numerical Simulation of Viscoelastic Deformation of Rubber Shock Absorbers Based on the Exponential Law. *Strength of Materials*, 54 (5), 776–784. <https://doi.org/10.1007/s11223-022-00454-8>
14. Çakmak, U. D., Major, Z. (2013). Experimental Thermomechanical Analysis of Elastomers Under Uni- and Biaxial Tensile Stress State. *Experimental Mechanics*, 54 (4), 653–663. <https://doi.org/10.1007/s11340-013-9820-8>
15. Choporov, S., Homeniuk, S., Grebenyuk, S. (2018). Optimized smoothing of discrete models of the implicitly defined geometrical objects' surfaces. *Eastern-European Journal of Enterprise Technologies*, 3 (4 (93)), 52–60. <https://doi.org/10.15587/1729-4061.2018.130787>
16. Re, D., De Angelis, F., Augusti, G., Augusti, D., Caputi, S., D'Amario, M., D'Arcangelo, C. (2015). Mechanical Properties of Elastomeric Impression Materials: An In Vitro Comparison. *International Journal of Dentistry*, 2015, 1–8. <https://doi.org/10.1155/2015/428286>
17. Rocker, S., Rayer, M., Ternes, S., Schiffers, R. (2023). Substitution of elastomer components under cyclic loading by thermoplastic elastomers: Investigations of static and dynamic properties. *Structural And Physical Aspects Of Construction Engineering 2022 (SPACE 2022): 5th International Scientific Conference*, 2950, 150002. <https://doi.org/10.1063/5.0168347>
18. Menning, J. D. M., Ewert, A., Prokopchuk, A., Schlecht, B., Henke, M., Wallmersperger, T. (2023). Finite element based modeling and simulation of an elastomer gear rim. *PAMM*, 23 (1). <https://doi.org/10.1002/pamm.202200141>
19. Piszko, P., Kryszak, B., Gazińska, M., Słota, D., Sobczak-Kupiec, A., Włodarczyk, M. et al. (2023). The effect of filler content on mechanical properties and cell response of elastomeric PGS/apatite foam scaffolds. *Ceramics International*, 49 (15), 25353–25363. <https://doi.org/10.1016/j.ceramint.2023.05.071>
20. Borreguero, A. M., Izarra, I., Garrido, I., Trzebiatowska, P. J., Datta, J., Serrano, A. et al. (2021). Thermal and Mechanical Behavior of Elastomers Incorporated with Thermoregulating Microcapsules. *Applied Sciences*, 11 (12), 5370. <https://doi.org/10.3390/app11125370>
21. Mezhuyev, V., Homenyuk, S., Lavrik, V. (2015). Computation of elastomers properties using FORTU-FEM CAD system. *ARPN Journal of Engineering and Applied Sciences*, 10 (20), 9167–9173. Available at: https://www.arpnjournals.org/jeas/research_papers/rp_2015/jeas_1115_2853.pdf
22. Coll, N., Guerrieri, M. (2017). Parallel constrained Delaunay triangulation on the GPU. *International Journal of Geographical Information Science*, 31 (7), 1467–1484. <https://doi.org/10.1080/13658816.2017.1300804>
23. Fayolle, P.-A., Pasko, A. (2012). Optimized surface discretization of functionally defined multi-material objects. *Advances in Engineering Software*, 45 (1), 301–312. <https://doi.org/10.1016/j.advengsoft.2011.10.007>
24. Choporov, S., Homeniuk, S., Grebenyuk, S., Kudin, O. (2019). Development of a method for triangulation of inhomogeneous regions represented by functions. *Eastern-European Journal of Enterprise Technologies*, 4 (4 (100)), 21–27. <https://doi.org/10.15587/1729-4061.2019.174010>
25. Hniezdovskyi, O., Kudin, O., Belokon, Y., Kruglyak, D., Ilin, S. (2022). Designing an object-oriented architecture for the finite element simulation of structural elements. *Eastern-European Journal of Enterprise Technologies*, 6 (2 (120)), 78–84. <https://doi.org/10.15587/1729-4061.2022.268018>
26. Havrylenko, Y., Cortez, J. I., Kholodniak, Y., Aliksieieva, H., Garcia, G. T. (2020). Modelling of Surfaces of Engineering Products on the Basis of Array of Points. *Tehnicki Vjesnik*, 27(6), 2034–2043. <https://doi.org/10.17559/tv-20190720081227>
27. Marinkovic, D., Zehn, M. (2019). Survey of Finite Element Method-Based Real-Time Simulations. *Applied Sciences*, 9 (14), 2775. <https://doi.org/10.3390/app9142775>
28. Hayemasae, N., Soontaranon, S., Rasidi, M. S. M., Masa, A. (2021). Tensile and structural properties of natural rubber vulcanizates with different mastication times. *Polímeros*, 31 (1). <https://doi.org/10.1590/0104-1428.09120>
29. Humova zirochka vid vyrobnyka. Ukrpromservis. Available at: <https://zavod-rti.com/gumova-zirochka-vid-virobnika/>